



HORIZONTAL DRUM SCREENS FOR
ORGANIC AND SOLID WASTE

TROMMEL SCREENS

HIGHLIGHTS

- Designed for continuous use, trouble-free screening performance and reliable drum cleaning
- Variable configuration options to adapt to any application and site
- Available Options:
 - Screen segment drum for changing segments without removing the drum
 - Special drum with anti-dirt strips for screening residual waste
 - Three-fraction screening by using different screen drum hole sizes

With Komptech stationary trommel screens, a corresponding screening machine is available for every system size. Direct-drive heavy-duty supporting wheels (1845/2055: Drum Grip drive) provide quiet drum operation and high efficiency with reduced energy consumption and noise emissions.

High-throughput screening performance is delivered by feed screws welded on the inner side of the screening drum. Variable configuration of the sub-structure, servicing accessibility, enclosure and drive help to simplify adaptation to a variety of operational conditions and requirements.



Komptech Trommel Screen Technology Overview

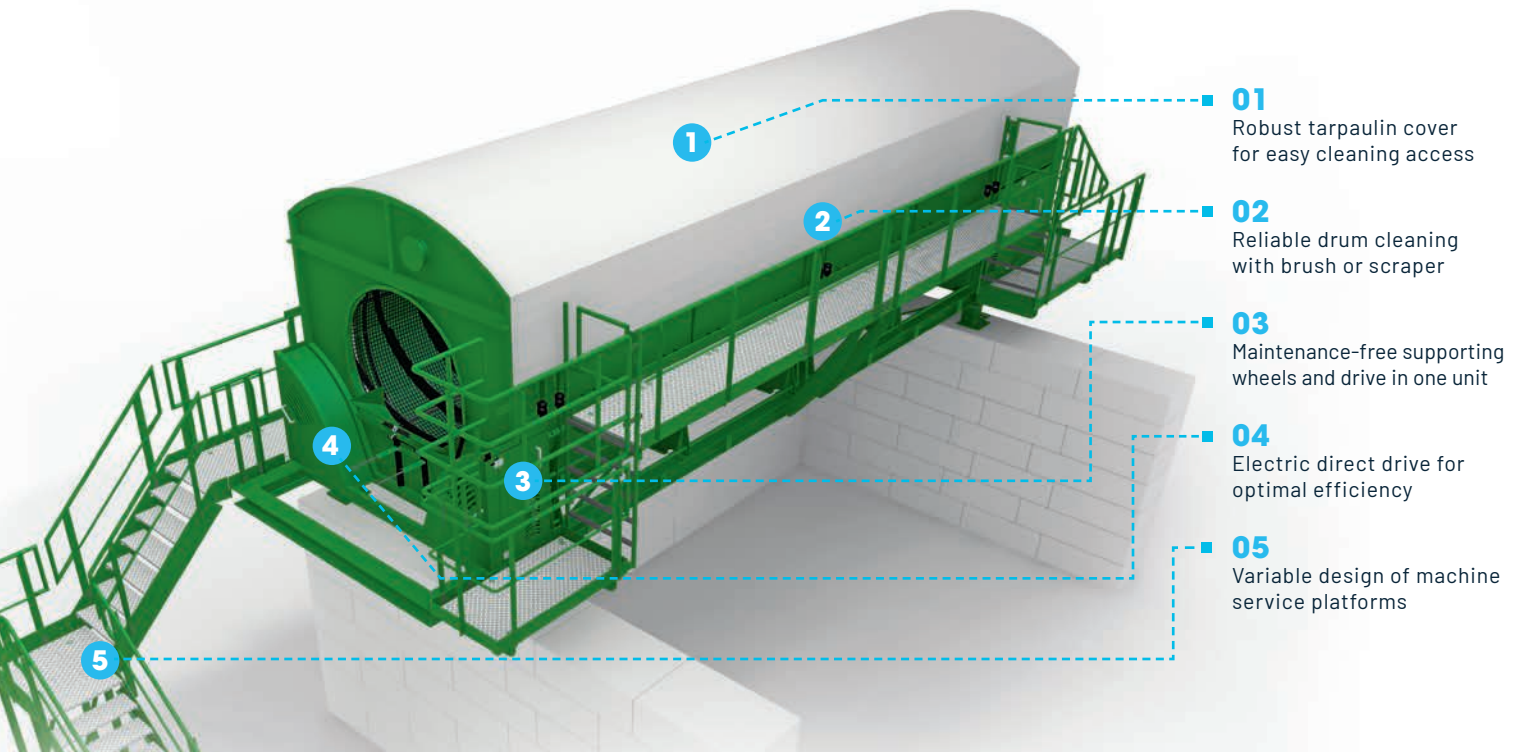

KOMPTECH STATIONARY TROMMEL SCREENS / Technical Specifications

Machine Model	1845	2055	2255	2278	2290	2590	25120
Power							
Electrical Power:	15 kW	18.5 kW or 4 x 4.0 kW	2 x 9.2 kW	2 x 11 kW	2 x 11 kW	4 x 7.5 kW	4 x 9.2 kW
System Type:	Drum Grip	Drum Grip or Direct Drive	Direct Drive	Direct Drive	Direct Drive	Direct Drive	Direct Drive
Proportion							
Drum Diameter:	5'11" (1.8 m)	6'7" (2 m)	7'2" (2.2 m)	7'2" (2.2 m)	7'2" (2.2 m)	8'2" (2.5 m)	8'2" (2.5 m)
Drum Length:	14'9" (4.5 m)	18'5" (5.5 m)	18'5" (5.5 m)	25'7" (7.8 m)	29'6" (9.0 m)	29'6" (9.0 m)	39'4" (12 m)
Effective Screening Area:	242 ft ² (22 m ²)	323 ft ² (30 m ²)	344 ft ² (32 m ²)	517 ft ² (48 m ²)	608 ft ² (57 m ²)	678 ft ² (63 m ²)	926 ft ² (86 m ²)
Drum Shell Area:	274 ft ² (25 m ²)	377 ft ² (35 m ²)	409 ft ² (38 m ²)	581 ft ² (54 m ²)	667 ft ² (62 m ²)	764 ft ² (71 m ²)	1,012 ft ² (94 m ²)
Machine Length*:	20'6" (6.2 m)	25'2" (7.6 m)	24'7" (7.5 m)	32'2" (9.8 m)	36'5" (11.1 m)	36'5" (11.1 m)	46'3" (14.1 m)
Machine Width*:	7'5" (2.2 m)	8'2" (2.5 m)	10'2" (3.1 m)	10'2" (3.1 m)	10'2" (3.1 m)	11'2" (3.4 m)	11'2" (3.4 m)
Machine Height*:	9'9" (2.9 m)	9'9" (2.9 m)	11'10" (3.6 m)	11'10" (3.6 m)	11'10" (3.6 m)	13'1" (4.0 m)	13'1" (4.0 m)
Performance <i>(dependent on material)</i>							
Max Throughput:	~42 tons/hr	~56 tons/hr	~67 tons/hr	~88 tons/hr	~88 tons/hr	~97 tons/hr	~106 tons/hr

* Machine dimensions shown are without catwalks/walkways included.