

# LACERO

## High-Speed, Horizontal Grinder



The Lacero 8010 is a high-speed horizontal grinder engineered and built for tough wood and green waste processing. Its extraordinary power, combined with a broad feed intake capacity, allows it to manage an incredible amount of material. This 812 HP high-speed horizontal grinder delivers high-volume production with maximum mobility for wood waste, biomass, mulch, and organic waste operations.

- ▶ 41" diameter, downswing drum with 16 carbide-coated teeth powered by a CAT® C18 engine
- ▶ Metal detection system with additional contamination protection
- ▶ Tracked unit with optional three axle dolly system for quick transportation

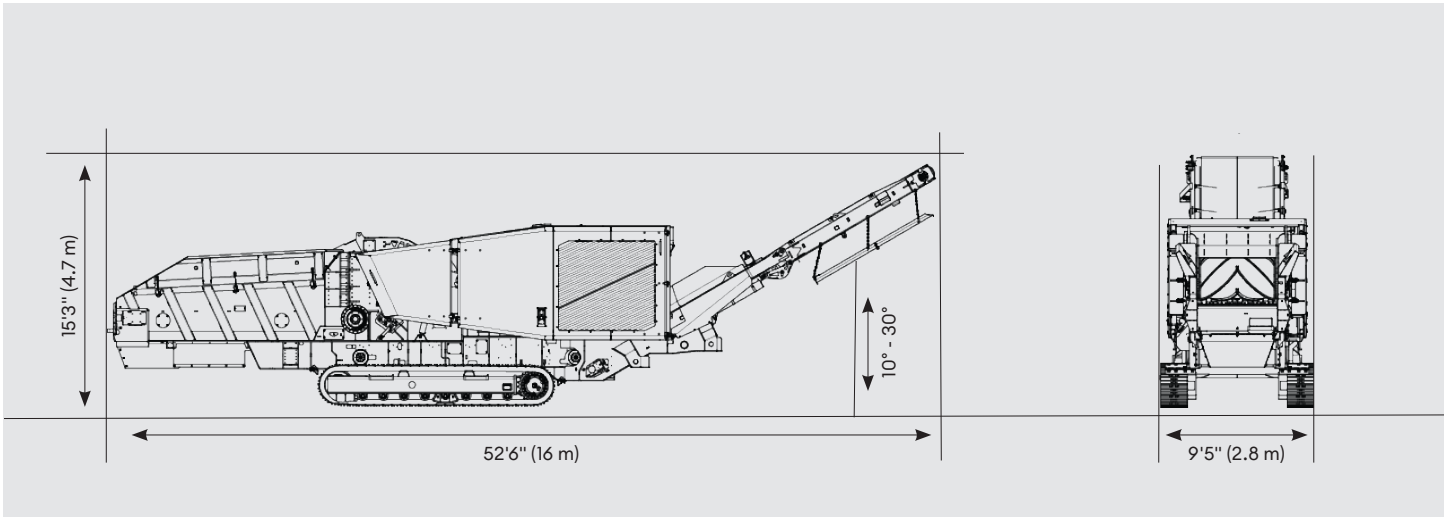

### LACERO Technical Specifications

|   |  |
|---|--|
| <b>Machine Model</b>                              | LACERO 8010  |
| <b>Power</b>                                      |  |
| Diesel Engine / Horsepower:                       | CAT® C18 Tier / 812 HP                                   |
| <b>Proportion</b> <i>(dependent on equipment)</i> |  |
| Transport Dimensions (LxWxH):                     | 44'4" x 9'5" x 12'4" (13.5 x 2.8 x 3.7 m)                |
| Working Dimensions (LxWxH):                       | 52'6" x 9'5" x 15'3" (16 x 2.8 x 4.7 m)                  |
| Feed Table Dimensions (LxWxH):                    | 13'10" x 4'11" x 7'11" (4.2 x 1.5 x 2.4 m)               |
| Infeed Opening Dimensions (HxW):                  | 2'7" x 4'11" (8 x 1.5 m)                                 |
| Drum Dimensions (Diameter x Width):               | 41.3" x 60.2" (1 x 1.5 m)                                |
| Weight:   | -90,000 lbs / -102,000 lbs (with dolly system)           |
| <b>Performance</b> <i>(dependent on material)</i> |  |
| Maximum Drum Speed:                               | 912 rpm  |
| Maximum Throughput:                               | up to -450 yd <sup>3</sup> /hr (-344 m <sup>3</sup> /hr) |